

**ORDINANCE NO. 4-13**  
(Replaces Ordinance 4-12)

AN ORDINANCE OF THE BOROUGH OF MERCERSBURG,  
FRANKLIN COUNTY, PENNSYLVANIA, REPLACING ORDINANCE 4-12, AN  
ORDINANCE REGULATING OPENINGS AND EXCAVATIONS IN OR UNDER  
THE STREETS AND HIGHWAYS OF THE BOROUGH OF MERCERSBURG

BE IT ENACTED AND ORDAINED, by the Mayor and Borough Council of the Borough of Mercersburg, Franklin County, Pennsylvania, and it is hereby enacted and ordained as follows:

**SECTION I. DEFINITIONS**

The following words and phrases when used in this article shall, for the purpose of this article, have the following meanings, respectively, except in those instances where the context clearly indicates a different meaning:

**BOROUGH** – The Borough of Mercersburg, Franklin County, Pennsylvania.

**ENGINEER** – The Engineer for the Borough of Mercersburg.

**PERMITTEE** – Any person to whom a permit may be issued under the terms of this article.

**PERSON** – Any individual, partnership, firm, corporation, association, trust, estate, or any other legal entity or their legal representatives, agents or assigns. The masculine gender shall include the feminine, the singular shall include the plural where indicated by context.

**STREET** – The cartway of any public street, highway, sidewalk, alley, avenue or other public grounds in the Borough of Mercersburg.

**NEWLY PAVED STREET** – A street in which both the base coat and the top coat have been replaced within the previous two calendar years.

**SECTION II. PERMIT REQUIRED**

It shall be unlawful for any person to make any opening or excavation in any street of the Borough of Mercersburg unless and until a permit therefore has been issued as hereinafter provided. The Borough Secretary shall issue permits under the conditions set forth in this article and upon approval from the Borough Manager, his/her designee, or the Borough Engineer. The Borough Manager, his/her designee, and Borough Engineer shall have the right to refuse to approve such permit, whenever in their judgment such opening or excavation would be hazardous or otherwise undesirable under the circumstances which exist for the particular conditions for which the permit has been requested. The terms of this ordinance shall not apply to the opening or excavation of any street by the Borough, Mercersburg Water Authority or Mercersburg Sewer Authority or by others for its account.

### SECTION III. APPLICATION FOR PERMIT

Any person wishing to make any opening or excavation in any street of the Borough shall, not less than ten (10) days in advance of the tentative time such work is to commence, submit an application for a permit to do such work. Such application shall be submitted on forms prepared by the Borough Secretary for such purpose and available at the office of the Borough Secretary. In all cases the application shall be submitted in the name of the person making and/or legally responsible for the opening or excavation as well as, if applicable, the property owner for whom the cut or excavation is being undertaken for. A separate application for a permit shall be submitted for each separate undertaking. In the event of any emergency in which a sewer or water main, conduit, pipe, or utility in or under any street breaks, bursts or otherwise is in such condition as to immediately endanger the property, life, health or safety of any individual, the person owning or controlling such sewer, main, conduit, pipe or utility, without first applying for and obtaining an excavation permit hereunder, shall immediately take proper emergency measures to cure or remedy the dangerous conditions. However, such person shall apply for an excavation permit not later than the end of the next succeeding day.

### SECTION IV. PERMIT FEE

A permit fee in the amount as set forth in the Borough Schedule of Fees and amended from time to time by Resolution of the Borough Council for the Borough of Mercersburg shall be charged by the Borough Secretary for the issuance of an Excavation Permit, which shall include inspection fees, with the following exceptions.

A. *Additional fees.* If the Borough anticipates that the cost of reviewing the required application information or inspecting the permitted work will exceed the application or inspection fees listed in the Borough Schedule of Fees, as amended from time to time by Resolution of the Borough Council for the Borough of Mercersburg, by a significant amount, the following additional fees will be assessed:

- (1) *Additional application fee.* The Borough will estimate the additional amount of salary, overhead and expenses, the permit will so indicate, and the permittee shall be charged for additional salary, overhead and expenses incurred by the Borough for administration.
- (2) *Additional inspection fees.* If the Borough determines that the permitted work is of sufficient magnitude or importance to warrant assignment of one or more persons to inspect the permitted work on a more than spot inspection basis, or more than the typical number of inspections are anticipated, the permit will so indicate and the permittee shall be charged for additional salary, overhead and expenses incurred by the Borough for inspection.
- (3) *Charge calculation.* The charges will be calculated either on an actual cost basis or a standard unit cost basis.

B. *Newly Paved Streets.* Should a permit be applied for to excavate within or open a newly paved street, a diminution fee will be added to the permit fees, as listed in the Borough Schedule of Fees, as amended from time to time by Resolution of the Borough Council for the Borough of Mercersburg.

NO permit shall be issued until all fees are received by the Borough Secretary.

SECTION V. FINANCIAL SECURITY AND INSURANCE REQUIRED

A. Before an excavation permit is issued, the applicant shall deposit with the Borough Secretary, Security in the form of a performance bond, irrevocable letter of credit, certified check, cash, or other security acceptable to the Borough, to be held without interest, in the amount as set forth in the Borough Schedule of Fees and amended from time to time by Resolution of the Borough Council for the Borough of Mercersburg, and also a certificate or other evidence to the Borough Secretary from an insurance company certifying that the permittee has comprehensive general liability insurance. The required security shall be conditioned upon completion of all work required as a result of the excavation which was made in the street and upon payment by the permittee of all costs incurred by the Borough and/or others as a result of such work. Prior to the Borough releasing the financial security, the Borough Manager, his/her designee, or Borough Engineer may inspect the excavation and determine whether all work was properly completed in accordance with the Typical Trench Details as depicted in this Ordinance. The security shall not be released or reduced unless the Borough Manager, his/her designee, or Borough Engineer has, in writing, certified the completion or partial completion of the street excavation.

B. The general liability insurance shall be written on a comprehensive form, including explosion coverage (if any blasting is to be involved), and hold the Borough and its officers harmless against any and all claims arising from the excavation permit or for which the Borough, Borough Council or any Borough officer may be made liable by reason of any accident or injury to persons or property through the fault of the permittee either in not properly guarding the excavation or for any other injury resulting from the negligence of the permittee. Recovery on such bond for any injury or accident shall not exhaust the bond, but it shall in its entirety cover any or all future accidents or injuries during the excavation work for which it is given. In the event of any suit or claim against the Borough by reason of the negligence or default of the permittee, upon the Borough's giving written notice to the permittee of such suit or claim, any final judgment against the Borough requiring it to pay for such damage shall be conclusive upon the permittee.

C. The aforesaid insurance policy for general liability is to protect the Borough and others against damage or claims arising out of the work, and the certificate of insurance shall provide that the policy shall be in force at the time of the application and cannot be canceled without 30 days prior notice to the Borough. Said bond and insurance certificate need not be submitted until the Borough Engineer has indicated a permit may be issued, but no permit shall be issued until said bond and certificate are submitted.

SECTION VI. PERMITTEE RESPONSIBILITIES DUE TO EXCESSIVE EXCAVATION

Should any permittee, person, or any sub-contractors working on behalf of a permittee or person, be responsible for four (4) distinct excavations or openings of a street, all of which are within one hundred linear feet (100') of one another, it shall be the responsibility of the permittee and/or person to overlay the entire width of the street corresponding to the one hundred linear feet (100') which contains the excavations with the following exception:

A. Should the street in which the excavations have been made be paved, i.e. the application

of a new base coat and top coat, by the Borough or on behalf of the Borough, between the first excavation and the fourth, the permittee shall not be held responsible for the overlay as described above.

#### SECTION VII. PROTECTIVE MEASURES

A. It shall be the duty of any person to whom a permit is issued or by whom any opening or excavation is made as aforesaid to provide and maintain proper and adequate guards, barriers and lights to prevent accidents, and they shall assume all risks and be liable for all damages by reason of the openings and excavations and by reason of any failure to properly fill the hole or trench and maintain the disturbed surface in a safe condition, and shall acknowledge that the permittee shall indemnify the Borough from any and all claims related to the excavation of the street in the application for a street opening permit.

B. The permittee shall be responsible for the safety of pedestrians and vehicular traffic during the course of his work and shall provide suitable barricades and warning lights and shall at all times maintain the flow of traffic upon the street within which the excavation is made, unless specific authority to close the street is obtained from the Chief of Police of the Borough with the concurrence of the Borough Manager. Watchmen shall be provided and kept on duty whenever necessary to maintain the proper flow of vehicular traffic or otherwise as required by the Borough.

C. If a permittee fails to institute adequate protective measures as required in this section, the Borough may in its discretion and in consideration of the public health, safety and welfare provide adequate safety measures. The permittee shall be responsible for any and all costs, including personnel time, which the Borough may incur, in any attempt to provide for the safety of pedestrians and/or vehicular traffic due to permittee's failure to institute adequate safety measures as required by this section. In no case shall the Borough assume liability for any of its attempts to provide for the safety of pedestrians and/or vehicular traffic and the permittee shall indemnify the Borough of any liability. Any costs charged under this subsection shall be paid within thirty (30) days of being invoiced to the permittee and shall be collected in any manner provided for by law.

#### SECTION VIII. RECTIFICATION OF IMPROPER OR INCOMPLETE WORK

If the street opening/excavation is not properly completed to the satisfaction of the Borough Manager, his/her designee, or Borough Engineer, the Borough Manager shall send written notification to the permittee and the property owner for whom the cut and excavation was undertaken for, which notification shall specify the defects and require repair, replacement, or completion to the satisfaction of the Borough Manager, his/her designee, or Borough Engineer within fifteen (15) days. If the cut/excavation is not repaired, replaced, or completed within fifteen (15) days the Borough may repair, replace, or complete the work in the manner deemed properly by the Borough Manager, his/her designee, or Borough Engineer and all costs related thereto shall be assessed to the permittee or the property owner for whom the cut or excavation was undertaken. Said costs shall be collected in any manner provided by law for the collection of municipal claims.

#### SECTION IX. BOROUGH WORK

A. Upon written request by any applicant for the Borough to perform the street openings on behalf of the applicant and upon the Borough's written assent to complete said work. An

excavation permit shall be issued to the applicant and delivered to the Borough, the Borough shall proceed with the excavation in accordance with the provisions of this article and the permittee shall be liable for the costs of the surface restoration and the costs of the excavation work as set forth in the Borough Schedule of Fees and amended from time to time by Resolution of the Borough Council.

B. If costs as set forth in Subsection A are not paid within 30 days of billing, they shall bear interest at the rate of 1.5% for each month thereof during which they remain unpaid and the said costs together with interest may be recovered in any manner provided by law for the collection of municipal claims.

SECTION X. VIOLATION AND PENALTIES

Any person violating any of the provisions of this ordinance and convicted before any District Justice shall be fined in an amount not to exceed \$500.00 for each and every offense and in default thereof to undergo imprisonment in the County Jail for a period not exceeding 30 days. Each day such a violation is committed or permitted to continue, shall constitute a separate offense and shall be punished as such hereunder. The permittee and any subcontractor violating the provisions of the article shall be separately and jointly liable to the penalty provisions.

SECTION XI. REPEALER

All provisions of previous Ordinances of the Borough of Mercersburg which are contrary to this Ordinance are expressly repealed.

SECTION XII. EFFECTIVE DATE

This Ordinance shall take effect five (5) days from its approval.

ENACTED, ORDAINED, AND APPROVED this 14<sup>th</sup> day of June, 2010

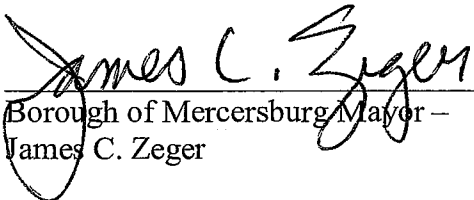
  
Borough of Mercersburg Mayor –  
James C. Zeger

  
Borough Council President –  
Elizabeth J. McClintick

ATTEST:

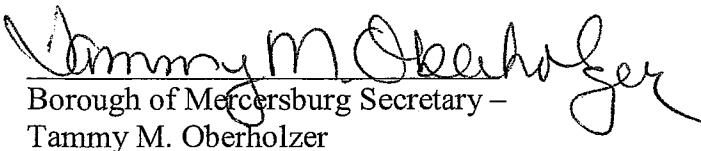
  
Borough of Mercersburg Secretary –  
Tammy M. Oberholzer

Approved this 14<sup>th</sup> day of June, 2010.

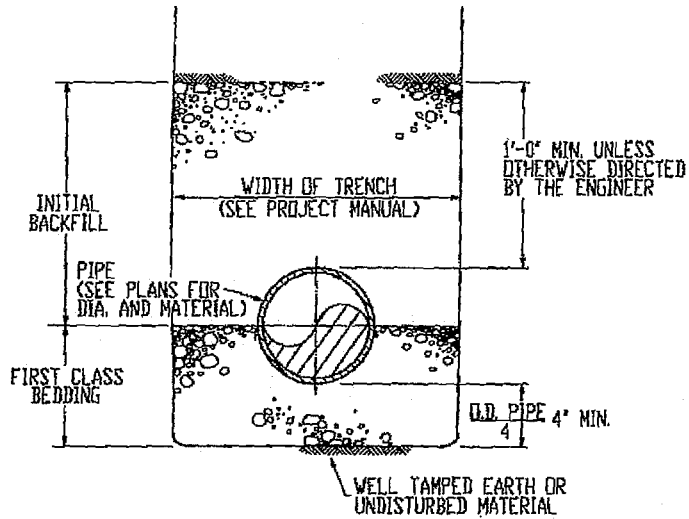

SECTIONAL ELEVATION  
FIRST CLASS BEDDING  
AND INITIAL BACKFILL  
PIPE BEDDING

(P-3)

PAINT EDGE OF EXISTING PAVING  
 w/ AE-T BITUMINOUS TACK  
 COAT BEFORE PAVING. AFTER  
 PAVING SEAL JOINT BETWEEN  
 NEW AND EXISTING PAVEMENT w/  
 AC-20 ASPHALT CEMENT.

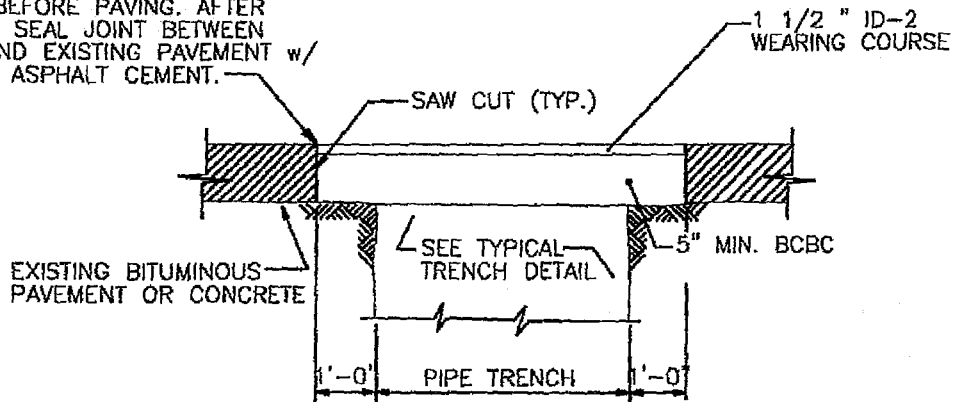

TOWNSHIP HIGHWAY/BOROUGH STREETS  
PAVEMENT REPLACEMENT

(TH-1)

NO SCALE

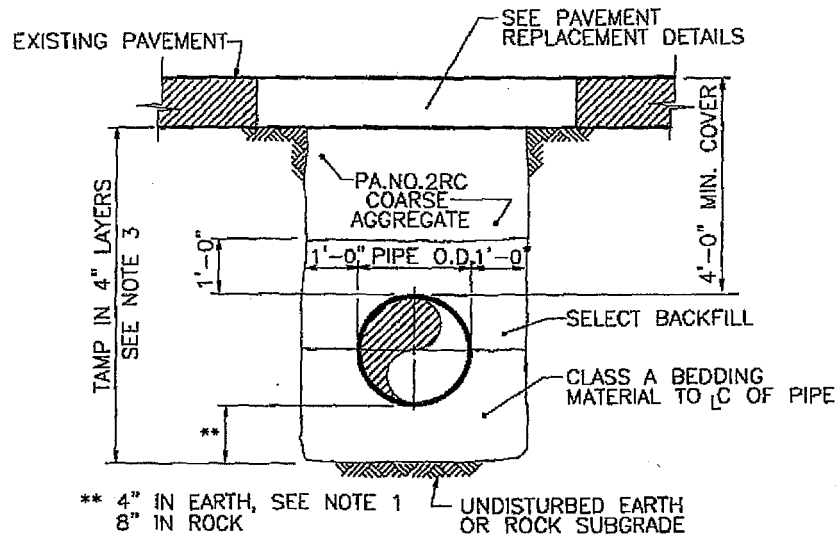

## TYPICAL TRENCH PAVED AREAS

NO SCALE

### TRENCH NOTES:

1. IF UNSUITABLE SUBSOIL IS ENCOUNTERED AT THE NORMAL TRENCH SUBGRADE, THE CONTRACTOR SHALL REMOVE IT TO THE DEPTH DIRECTED BY THE ENGINEER IN THE FIELD, AND BACKFILL W/ CLASS 'A' BEDDING MATERIAL IN 4" LAYERS.
2. BOTTOM OF TRENCH SHALL BE FREE OF WATER PRIOR TO PLACING BEDDING.
3. IF VIBRATORY COMPACTION EQUIPMENT IS USED BACKFILL MAY BE IN 8" LAYERS.
4. PROVIDE 4" OF TOPSOIL WHERE SEEDING IS REQUIRED, SEE NOTE 6 AT GRAVEL DRIVEWAYS.
5. CONTRACTOR SHALL SHORE THE TRENCH IN ACCORDANCE WITH SECTION 02151 OF THE SPECIFICATIONS.
6. GRAVEL AND PAVED DRIVEWAYS TO BE RESTORED IN KIND WITH MINIMUM REQUIREMENTS AS INDICATED ON THIS SHEET.